

DW9738

Bi-direction Driver IC with 16Kbyte

Description

DW9738 is designed for linear control of bi-direction voice coil motors (Bi-VCM). The DW9738 is a single 10-bit DAC with $\pm 100\text{mA}/\pm 130\text{mA}$ output current sinking capability and has an 16Kbyte EEPROM memory. The Smart Actuator Control (SAC™) mode which can minimize the mechanical vibration and achieve very fast settling time. The SAC™ is protected by patent and registered trademark of DONGWOON ANATECH.

The DW9738 operates from 2.65V to 3.3V supply. The internal DAC (Digital to Analog Converter) and EEPROM are controlled via an I²C serial interface that operation clock rate can be up to 1MHz.

The DW9738 can be used for AF (Auto Focus) applications in mobile cameras, digital still cameras, camcorders, web cameras and action cameras.

Features

- $\pm 100\text{mA}/\pm 130\text{mA}$, 10-bit resolution DAC
- Embedded 16Kbyte EEPROM
- Smart Actuator Control (SAC™) mode
- Supply voltage range (VDD): 2.65V to 3.3V
- I/O voltage range (VIO): 1.8V to VDD
- Fast mode and Fast mode plus I²C interface compatible
- Power On Reset (POR)
- Package: 6-pin WLCSP, 0.78mm x 1.51mm x 0.3mm

Applications

- Mobile cameras
- Digital still cameras
- Camcorders
- Web cameras
- Action Cameras

Typical Application Diagram

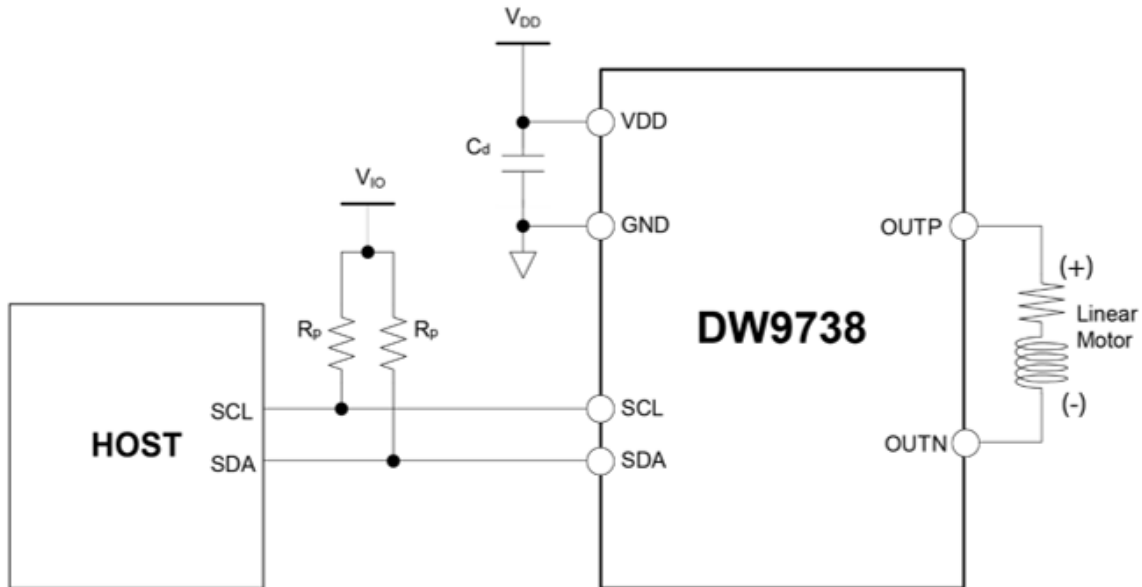

Figure 1. Typical Application Diagram

Important Notice

HMI reserves the rights to modify, update, improve, and discontinue its products, services, documentations and more without advance notice. We encourage customers to contact HMI's sales representative for the most up to date product information.

HMI's products, solutions, and documents must not be used for any medical or military purposes without a proper legal authorization from HMI. HMI disclaims any responsibilities and liabilities for personal or property damages arising from such applications.

All content, visuals, trademarks within this document, and any other intellectual property embedded in the product and document remains the sole property of HMI. Reproduction, alteration, distribution, or publication of any part or whole of this document is prohibited without legal consent from HMI.