

# HL5095K

## Back-to-Back OVP with Adjustable Current Limit

### Description

The HL5095 is a slew-rate controlled, low  $R_{ds(on)}$  Over voltage protection device. It is used in between a power source and a load to protect and isolate power source against unwanted abnormal voltage and current condition. Especially, in the OTG mode of smartphone, the HL5095 could be placed between OTG boost regulator and USB port. The HL5095 can protect boost regulator in smartphone from the USB fault conditions like overvoltage or overcurrent condition.

In order to be used at high voltage application (9V or above), the HL5095A/HL5095KA and HL5095B/HL5095KB apply a high voltage device power FET switch and a maximum input voltage is 13.5V. Its over voltage protection level is set to 14.2V in HL5095A/HL5095KA version, 10.4V in HL5095B/HL5095KB and 5.8V in HL5095C/HL5095KC.

To prevent excessive input voltage or battery droop resulting from a large inrush current, the HL5095 also implements several protection functions, such as output over voltage and input under-voltage protection, over-current protection with FLT flag and over-temperature protection.

HL5095 is available in a 9-pin WLCSP package.

### Features

- Input Voltage Range:
  - HL5095A, HL5095KA: 2.5V ~ 13.5V
  - HL5095B, HL5095KB: 2.5V ~ 10V
  - HL5095C, HL5095KC: 2.5V ~ 5.5V
- 28V Absolute Maximum Voltage Rating of VOUT
- Adjustable Current Limit with external resistor
- Integrated Power FET switch with 53m $\Omega$   $R_{ds(on)}$  @ 5V/1A
- Built in Soft Start to prevent inrush current
- Protection
  - Over Temperature Protection (OTP)
  - Over Voltage Protection (OVP):
    - HL5095A, HL5095KA: 14.2V
    - HL5095B, HL5095KB: 10.4V
    - HL5095C, HL5095KC: 5.8V
  - Over Current Protection
  - Reverse Current Protection
- Compliance to IEC61000-4-2 on VOUT
  - Contact discharge:  $\pm 8$ kV
  - Air Gap discharge:  $\pm 15$ kV
- Package:
  - HL5095A, HL5095B, HL5095C: 9-Bump WLCSP, 0.4mm Pitch, 1.23mm x 1.23mm
  - HL5095KA, HL5095KB, HL5095KC: 9-Bump WLCSP, 0.4mm Pitch, 1.22mm x 1.22mm



## **Applications**

- Smart Phone
- Tablet PC
- Notebook PC
- Mobile IoT Devices

## Typical Application Diagram

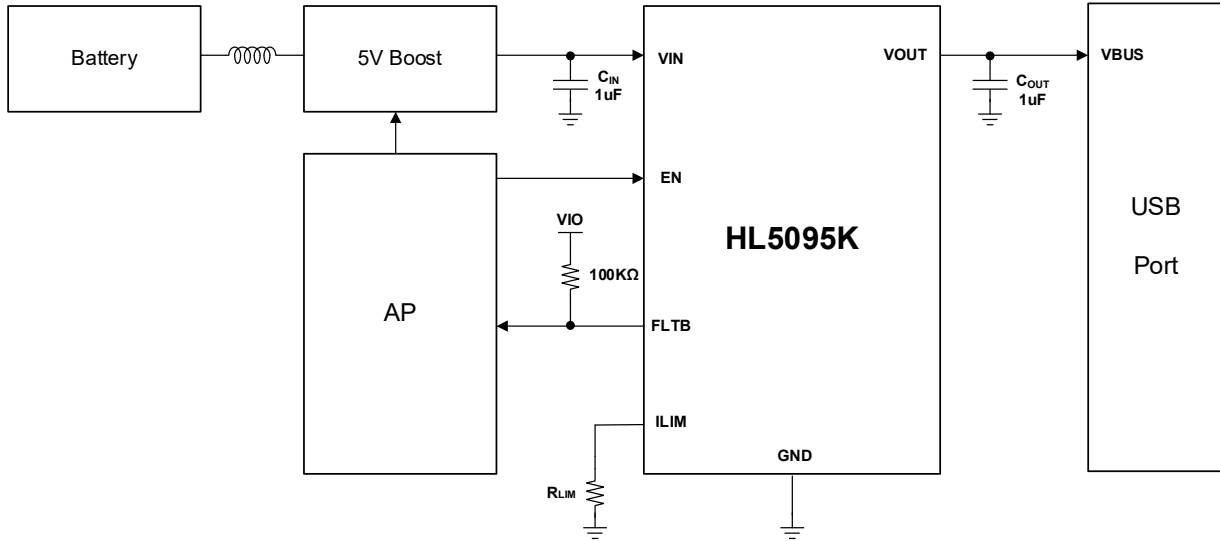

Figure 1. Typical Application Diagram

## Order Information

| Part Number                                | VOUT OVP threshold | Package | Packing Method |
|--|--------------------|---------|----------------|
| HL5095AWL01<br>HL5095KAWL01 <sup>(1)</sup> | 14.2V              | WLCSP-9 | Tape & Reel    |
| HL5095BWL01<br>HL5095KBWL01 <sup>(1)</sup> | 10.4V              | WLCSP-9 | Tape & Reel    |
| HL5095CWL01<br>HL5095KCWL01 <sup>(1)</sup> | 5.8V               | WLCSP-9 | Tape & Reel    |

## **Important Notice**

HMI reserves the rights to modify, update, improve, and discontinue its products, services, documentations and more without advance notice. We encourage customers to contact HMI's sales representative for the most up to date product information.

HMI's products, solutions, and documents must not be used for any medical or military purposes without a proper legal authorization from HMI. HMI disclaims any responsibilities and liabilities for personal or property damages arising from such applications.

All content, visuals, trademarks within this document, and any other intellectual property embedded in the product and document remains the sole property of HMI. Reproduction, alteration, distribution, or publication of any part or whole of this document is prohibited without legal consent from HMI.