

HL7504

3MHz 2A Buck Converter in DFN Package

Description

HL7504 is a synchronous buck converter optimized to supply different sub systems of portable applications. Its input voltage range is 2.5V to 5.5V. Its output voltage is a factory pre-set value between 1.05V and 3.3V.

HL7504 can deliver up to 2.0A with 80% efficiency, while maintaining over 80% efficiency at load currents as low as 10mA. It operates at a high frequency of 3MHz, which greatly reduces the value of the external components. A wide range of output capacitors can be used to optimize VOUT stability during load transients. Inductors from 1.0uH to 2.2uH may be used without affecting loop stability.

At moderate to light loads, Pulse Frequency Modulation (PFM) is used to maintain conversion efficiency with a typical non-switching quiescent current of 60 μ A. Even with such a low quiescent current, HL7504 maintains excellent load and line transient responses. At higher loads, the system automatically switches to fixed-frequency Pulse Width Modulation (PWM) operation at 3MHz for minimum VOUT ripple and optimal load transient response. In Shutdown Mode, the supply current drops below 1 μ A, reducing power consumption.

The HL7504 is available in 2 x 2mm DFN-6 Package.

Features

- Input Voltage Range: 2.5V~5.5V
- Output Voltage:
1.20V, 1.86V, 3.30V, 1.05V, 1.50V, 1.80V,
1.10V, 3.10V, 1.08V
- Maximum Output Current: 2A
- 3MHz PWM with Seamless PWM/PFM
Switching for Light-load Efficiency
- Excellent Load and Line Transient
- Quiescent Current in PFM Tristate: 60uA
- Comprehensive Protection
 - Input Under-Voltage Lockout (UVLO)
 - Input Over-Voltage Lockout (OVLO)
 - Over Current and Short-Circuit
Protection
 - Thermal Shut-down
- Active Discharge When Disabled
- Automatic PFM
- Enable Input
- Power Good Output
- Soft Start
- 2mm x 2mm DFN-6 Package

Applications

- Memory, Hard Disk Drive and SSD
- Data Cards
- Smart Phones
- Tablets
- Handheld Devices

Typical Application Diagram

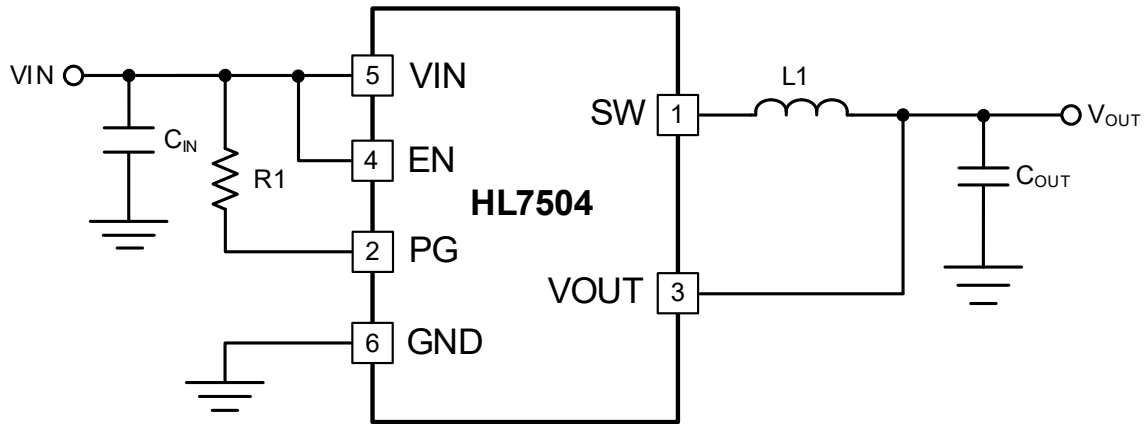

Figure 1. Typical Application Diagram

Order Information

Part Number	V _{OUT}	Max Load Current	Pin 2 Function	Soft-Start (t _{SS})	Package	Packing Method
HL7504FN01	1.20V	2A	Power Good	1ms	DFN-6	Tape & Reel
HL7504FN02	1.86V	2A	Power Good	1ms		
HL7504FN03	3.30V	2A	Power Good	1ms		
HL7504FN04	1.05V	2A	Power Good	1ms		
HL7504FN06	1.50V	2A	Power Good	1ms		
HL7504FN07	1.80V	2A	Power Good	300μs		
HL7504FN08	1.10V	2A	Power Good	300μs		
HL7504FN09	3.10V	2A	Power Good	300μs		
HL7504FN10	1.08V	2A	Power Good	300μs		

For other default output voltage and maximum load current options, contact a HMI sales representative.

Important Notice

HMI reserves the rights to modify, update, improve, and discontinue its products, services, documentations and more without advance notice. We encourage customers to contact HMI's sales representative for the most up to date product information.

HMI's products, solutions, and documents must not be used for any medical or military purposes without a proper legal authorization from HMI. HMI disclaims any responsibilities and liabilities for personal or property damages arising from such applications.

All content, visuals, trademarks within this document, and any other intellectual property embedded in the product and document remains the sole property of HMI. Reproduction, alteration, distribution, or publication of any part or whole of this document is prohibited without legal consent from HMI.