

# HL7593

## I<sup>2</sup>C Programmable 3A DVS Buck Converter

### Description

HL7593 is a synchronous buck converter optimized to supply different sub systems of portable applications. Its input voltage range is 2.5V to 5.5V. Its output voltage range is 0.600V to 1.394V in 6.25mV steps, programmed through an I<sup>2</sup>C interface. Its output voltage can be adjusted on the fly to provide Dynamic Voltage Scaling (DVS) function with a programmable slew rate.

HL7593 can deliver up to 86% efficiency 3A output current and maintain over 80% efficiency at 10mA or higher light load currents. It operates at fixed frequency of 2.4MHz, which reduces the value and size of the external components. A wide range of output capacitors can be used to optimize output load transient performances. Inductors from 0.24uH to 1.0uH may be used without affecting loop stability. For maximum 3A output load, Inductors from 0.33uH to 1.0uH is recommended.

At moderate to light loads, Pulse Frequency Modulation (PFM) is used to maintain conversion efficiency with a typical non-switching quiescent current of 48µA. Even with such a low quiescent current, HL7593 maintains excellent load and line transient responses. At higher loads, the system automatically switches to fixed-frequency Pulse Width Modulation (PWM) operation at 2.4MHz for minimum VOUT ripple and optimal load transient response. In Shutdown Mode, the supply current drops below 1µA, reducing power consumption. PFM Mode can be disabled if needed through I<sup>2</sup>C registers. HL7593 supports VOUT remote sensing. It's feedback signal VOUT can be connected close to the power supply pin of the load for a true point-of-load operation without affecting control loop stability.

The HL7593 is available in a 15-bump, 0.4mm pitch, 2.01mm x 1.21mm WLCSP.

## Features

- Input Voltage Operation Range: 2.5V~5.5V
- Programmable Output Voltage:
  - 0.600V to 1.394V in 6.25 mV/Step
- Maximum Output Current: 3A
- Fixed 2.4 MHz Switching Frequency
- Seamless PWM/PFM Mode Switching for High Efficiency at Light-load
- Output Dynamic Voltage Scaling (DVS) with Programmable Voltage Slew Rate
  - 0.5mV to 64mV/step
- Excellent Load and Line Transients
- Quiescent Current in PFM Mode: 48μA
- I<sup>2</sup>C Interface with SM, FM, FM+ and HS Modes
- Comprehensive Protection
- Input Under-Voltage Lockout (UVLO)
- Input Over-Voltage Protection (OVP)
- Over Current and Short-Circuit Protection
- Thermal Shut-down
- 2.01mm x 1.21mm 15-Bump WLCSP Package

## Applications

- Application Processors
- Memory, Hard Disk Drive and SSD
- Smart Phones
- Tablets
- Handheld Devices

### Typical Application Diagram

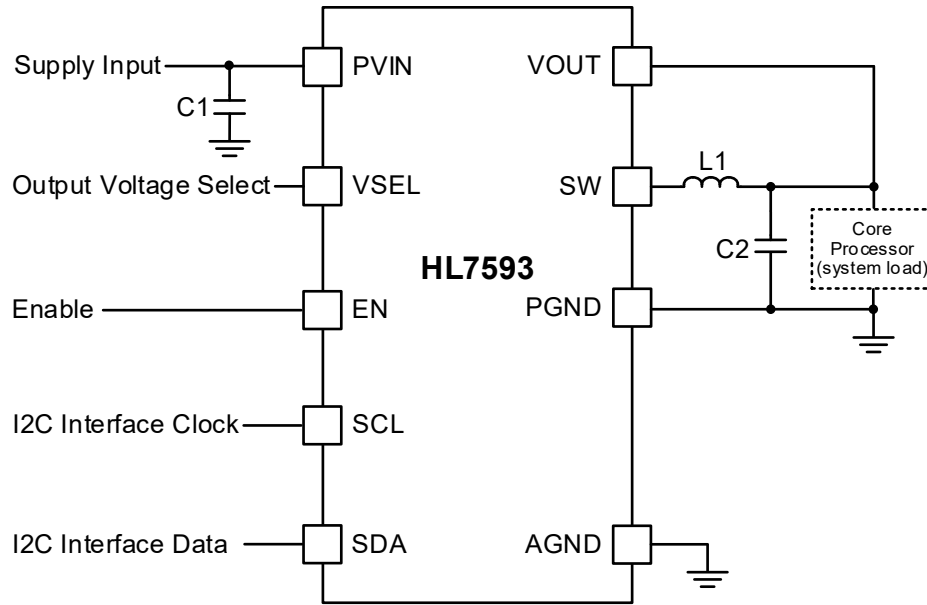

Figure 1. Typical Application Diagram

## Order Information

Part Number	Default V <sub>OUT</sub> after POR		Default mode after POR		I <sup>2</sup> C Address	Package	Packing Method
	VSEL=0	VSEL=1	VSEL=0	VSEL=1			
HL7593WL01 HL7593HWL01 <sup>(1)</sup>	0.600V	0.600V	Auto PFM	Forced PWM	1010 000	WLCSP	Tape & Reel
HL7593WL02 HL7593HWL02 <sup>(1)</sup>	1.125V	1.125V	Auto PFM	Forced PWM	1010 111	WLCSP	Tape & Reel
HL7593WL04 HL7593HWL04 <sup>(1)</sup>	0.900V	0.900V	Auto PFM	Auto PFM	1010 101	WLCSP	Tape & Reel
HL7593WL06 HL7593HWL06 <sup>(1)</sup>	0.800V	0.800V	Forced PWM	Auto PFM	1100 001	WLCSP	Tape & Reel
HL7593WL07 HL7593HWL07 <sup>(1)</sup>	1.200V	1.200V	Auto PFM	Forced PWM	1100 000	WLCSP	Tape & Reel
HL7593WL08 HL7593HWL08 <sup>(1)</sup>	1.05V	1.05V	Auto PFM	Forced PWM	1010 111	WLCSP	Tape & Reel
HL7593WL0A HL7593HWL0A <sup>(1)</sup>	0.750V	0.750V	Auto PFM	Forced PWM	1100 001	WLCSP	Tape & Reel

## **Important Notice**

HMI reserves the rights to modify, update, improve, and discontinue its products, services, documentations and more without advance notice. We encourage customers to contact HMI's sales representative for the most up to date product information.

HMI's products, solutions, and documents must not be used for any medical or military purposes without a proper legal authorization from HMI. HMI disclaims any responsibilities and liabilities for personal or property damages arising from such applications.

All content, visuals, trademarks within this document, and any other intellectual property embedded in the product and document remains the sole property of HMI. Reproduction, alteration, distribution, or publication of any part or whole of this document is prohibited without legal consent from HMI.